

Product Features

- Input voltage range: 90~305Vac;
- Constant power design, outputs programmable;
- Built-in 3-in-1 dimming and auto-react: 0-10Vdc, PWM, timer control;
- DALI control is optional, can be dim-to-off;
- 12V/0.3A auxiliary power supply is optional;
- Output is isolated with dimming signal;
- Stand-by power consumption <0.5W;
- Multiple protection: SCP / OVP/OTP;
- Surge protection: line-line 5KV, line-earth 10KV;
- Ambient temperature: -40°C ~ +60°C;
- Degrees of protection: IP67;
- 5 years warranty.



Application

- Suitable for LED architecture lighting, industrial lighting, flood lighting, and roadway lighting, etc.

DESCRIPTION

The GLUP-120 series is programmable outdoor LED driver that operates from 90-305Vac input with excellent power factor. Created for high bay, tunnel and roadway lights, it provides a dim-to-off mode with low standby power. The high efficiency of these drivers and compact metal case enables them to run cooler, significantly improving reliability and extending product life. To ensure trouble-free operation, protection is provided against input surge, output over voltage, short circuit, and over temperature.

MODELS

Model Number [1]	Max Output Power (W)	Output Voltage Range (Vdc)	Output Current Adjustable Range (A)	Full Power Current Adjustable Range (A) [2]	Default Output Setting	Typ. Effi. [3]	Typ. PF
GLUP-120X041Z	120	20~41	0.43~4.29	2.93~4.29	20~36V/3.33A	91%	0.96
GLUP-120X062Z	120	20~62	0.30~3.00	1.93~3.00	20~48V/2.50A	92%	0.96
GLUP-120X170Z	120	60 ~ 170	0.14 ~ 1.40	0.70 ~ 1.40	60~114V/1.05A	92%	0.96
GLUP-120X305Z	120	120 ~ 305	0.07~0.70	0.40~0.70	120~171V/0.7A	92%	0.96

Notes:

- [1]. X=M, programable output with 0-10V/PWM/Timing dimming ; X=R, programable output with timing dimming ; X=D, dali dimming; Z=A12,output with 12V/0.2A auxiliary power supply;
- [2]. Output current adjustable range with constant power at max output power;
- [3]. All specifications are measured at 25°C ambient temperature, if no specific note.

OPERATING AREA I-V

GLUP-120X041Z

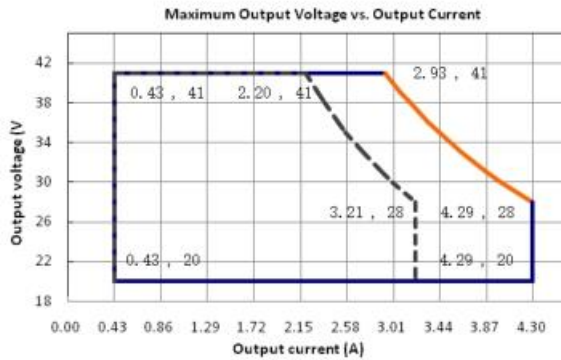

GLUP-120X062Z

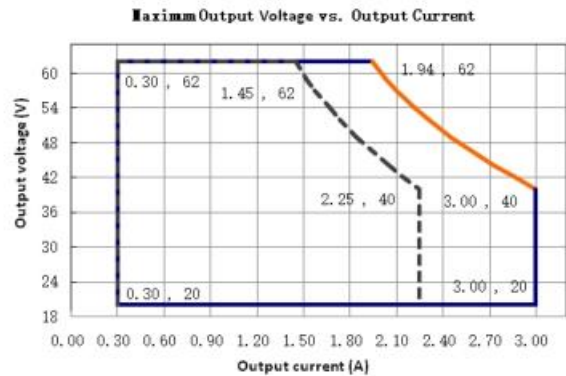

GLUP-120X170Z

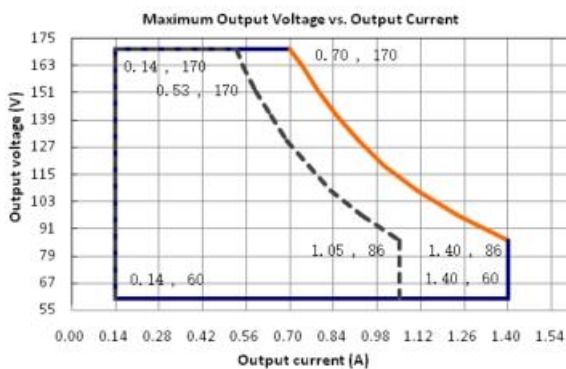

GLUP-120X305Z

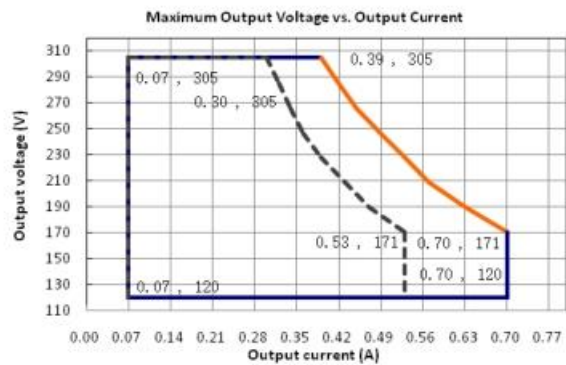

Note: 90W is suitable for the dotted line on the left side area; 120W is suitable for the solid line contain area.

INPUT SPECIFICATIONS

Parameter	Min.	Typ.	Max.	Notes
Input Voltage	90Vac	100-277Vac	305Vac	
Input Frequency	47Hz	50/60	63Hz	
Leakage Current	-	-	0.75Ma	277V/50Hz
Input AC Current	-	-	1.5A max	100-277Vac & full load
Inrush Current(A)	-	-	75A	Cold start, 230Vac & full load
Power Factor	0.95	0.96	-	230Vac & full load
THD	-	-	15%	230Vac, 70%-100% load
	-	-	20%	277Vac, 70%-100% load

OUTPUT SPECIFICATIONS

Parameter	Min.	Typ.	Max.	Notes
Rated Power	-	-	120W	200-277Vac
	-	-	90W	100-200Vac
Output Current Tolerance	-5%Iset	-	5%Iset	Full load
Output Current Setting Range (Iset) GLUP-120X041Z GLUP-120X062Z GLUP-120X170Z GLUP-120X305Z	0.43A 0.30A 0.14A 0.07A	-	4.29A 3.00A 1.40A 0.70A	200-277Vac
Output Current Setting Range with Constant Power GLUP-120X041Z GLUP-120X062Z GLUP-120X170Z GLUP-120X305Z	2.93A 1.93A 0.70A 0.40A	-	4.29A 3.00A 1.40A 0.70A	200-277Vac
Total Output Current Ripple (pk-pk)	-	-	10%	Load is LED, ripple is different with difference LED load. 20MHz BW.
Startup Overshoot Current		-	10%	230Vac & 100% Load, load is LED
No Load Output Voltage GLUP-120X041Z GLUP-120X062Z GLUP-120X170Z GLUP-120X305Z	-	-	60V 80V 190V 340V	
Line Regulation	-	-	1%	25°C±10°C ambient temperature, input voltage changes from 115Vac to
Load Regulation	-	-	3%	25°C±10°C ambient temperature, 230Vac input, load changes from 50% to 100%.
Turn-on Delay Time	-	-	3S	115Vac, 100% load
	-	-	0.5S	230Vac, 100% load
12V auxiliary output voltage	11.4V	12V	12.6V	
12V auxiliary output source current	0mA		300mA	

GENERAL SPECIFICATIONS

Parameter	Min.	Typ.	Max.	Notes		
Efficiency @115Vac GLUP-120X041Z I _o = 2.2A GLUP-120X062Z I _o = 1.45A GLUP-120X170Z I _o = 0.53A GLUP-120X305Z I _o = 0.30A	86%	88%		Measured at full load and 25°C ambient temperature		
Efficiency @230Vac GLUP-120X041Z I _o = 2.93A I _o = 4.29A GLUP-120X062Z I _o = 1.93A I _o = 3.00A GLUP-120X170Z I _o = 0.70A I _o = 1.40A GLUP-120X305Z I _o = 0.40A I _o = 0.70A	88% 87%	90% 89%			Measured at full load and 25°C ambient temperature	
Efficiency @277Vac GLUP-120X041Z I _o = 2.93A I _o = 4.29A GLUP-120X062Z I _o = 1.93A I _o = 3.00A GLUP-120X170Z I _o = 0.70A I _o = 1.40A GLUP-120X305Z I _o = 0.40A I _o = 0.70A	88% 87%	90% 89%				Measured at full load and 25°C ambient temperature
Standby power consumption	-	-	0.5W			
MTBF	-	200000 Hours	-	230Vac, 80% load (MIL-HDBK-217F)		
Lifetime	-	50000 Hours	-	230Vac & 100% load, 70°C case temperature, refer to lifetime VS T _c curve for details		
Operating Case Temperature for Safety T _{c_s}	-40°C	-	+85°C			
Operating Case Temperature for Warranty T _{c_w}	-40°C	-	+70°C			
Storage Temperature	-40°C	-	+85°C	Humidity: 10% to 95% RH		
Dimensions (L×W×H)mm	217*68*43.5					
Net Weight	950±50g					
Package	L500×W390×H170mm; 10pcs/Ctn					

DIMMING

Parameter		Min.	Typ.	Max.	Notes
0~5V/0~10V Absolute Maximum Voltage on the Vdim (+) Pin		-	5V/10V	-	
0~5V/0~10V Source Current on Vdim(+)Pin		-	-	2mA	
Dimming Output Range	GLUP-120X041Z GLUP-120X062Z GLUP-120X170Z GLUP-120X305Z	10%Imax	-	100%Imax	Imax=4.29A Imax=3.00A Imax=1.40A Imax=0.70A
	GLUP-120X041Z GLUP-120X062Z GLUP-120X170Z GLUP-120X305Z	0.43A 0.30A 0.14A 0.07A	-	4.29A 3.00A 1.40A 0.70A	
DA, DA High Level		9.5 V	16 V	22.5 V	
DA, DA Low Level		-6.5 V	0 V	6.5 V	
Recommended Dimming Range for 0-5 V		0V	-	5V	
Recommended Dimming Range for 0-10 V		0V	-	10V	Default 0-10V/10V PWM Dimming
PWM_in High Level		9.7V	-	10.3V	
PWM_in Low Level		0V	-	0.3V	
PWM_in Frequency Range		250Hz		1000Hz	
PWM_in Duty Cycle		1%	-	99%	

SAFETY STANDARDS

Safety Category	Country / Territory	Standards
CCC	China	GB19510.1
		GB19510.14
CE	Europe	EN61347-1
		EN61347-2-13
CB	CB Countries	IEC61347-1
		IEC61347-2-13
UL	USA	UL 8750
		UL 1310 (Class 2 Power Units)
		UL 1012
cUL	Canada	CSA C22.2 No.250.13-12
		CSA C22.2 No.223-M91 (Power Supplies With Extra-Low-Voltage Class 2 Outputs)
KC	South Korea	K61347-1
		K61347-2-13
		K62384
PSE	Japan	J61347-1
		J61347-2-13
SAA	Australia	AS/NZS IEC 61347-2-13
		AS/NZS 61347.1

EMC COMPLIANCE

EMC Category	Country / Territory	Standards
CCC	China	GB 17743
		GB 17625.1
CE	Europe	EN 55015
		EN 61000-3-2
		EN 61000-3-3
		EN 61547
KC	South Korea	K61547
		K00015
PSE	Japan	J55015
FCC	USA	FCC part 15

NOTE:

This LED driver meets the EMI specifications above, but EMI performance of a luminaire that contains it depends also on the other devices connected to the driver and on the fixture itself.

DALI STANDARDS

IEC 62386 -101, 102, 207.

INRUSH CURRENT WAVEFORM

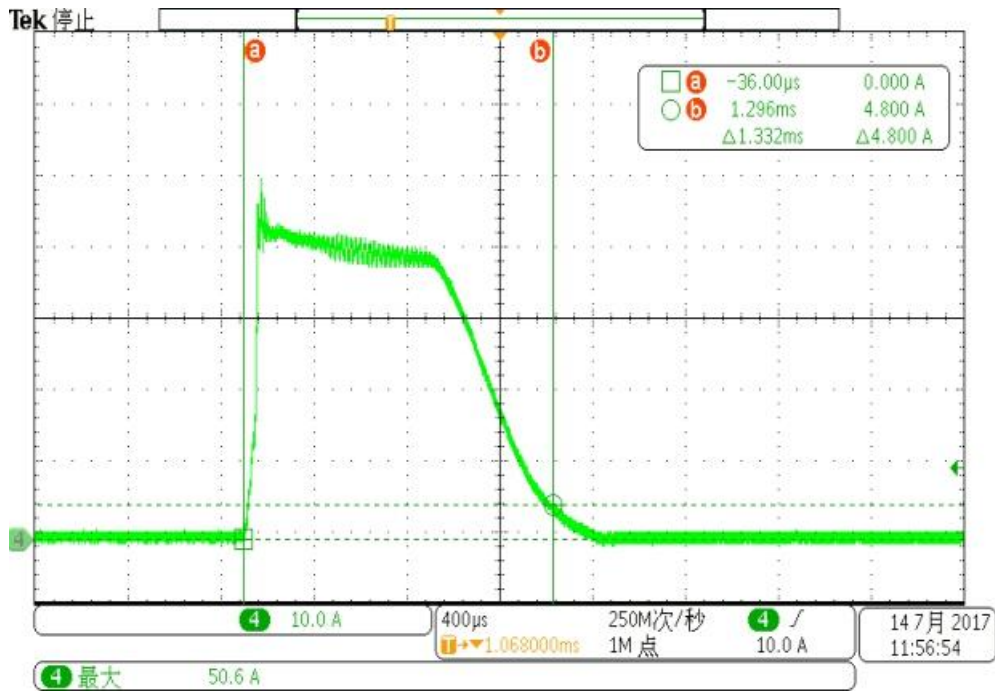

DERATING CURVE

Derating Curve

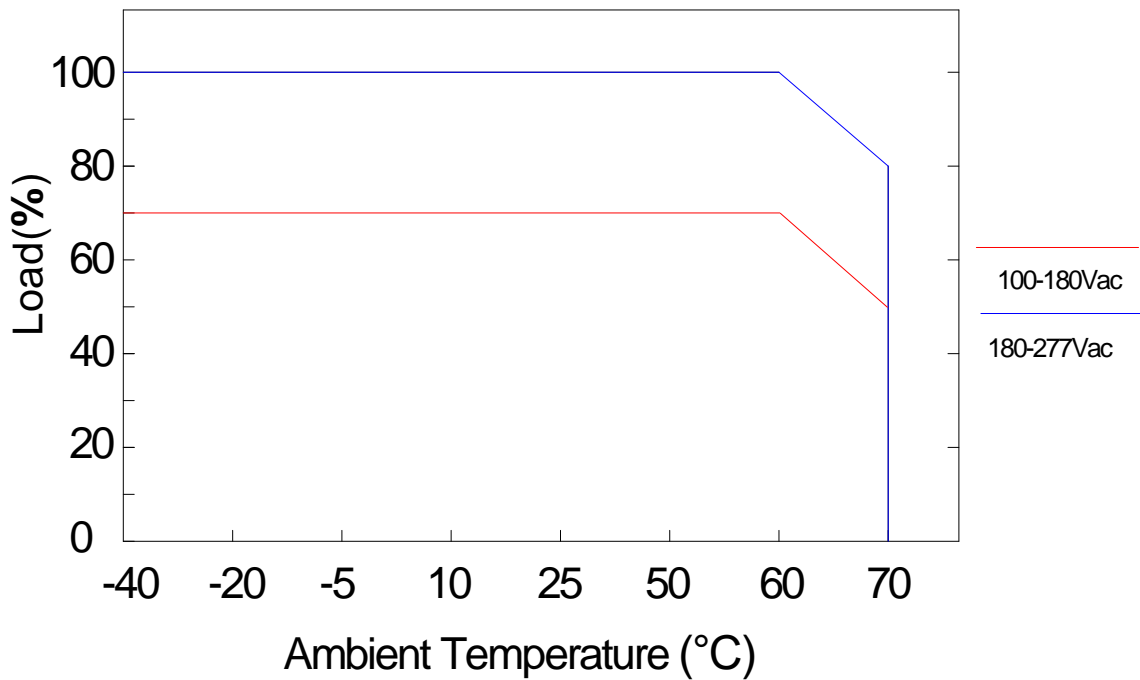

OUTPUT POWER VS INPUT VOLTAGE

Po/Pmax vs. Input Voltage Curve

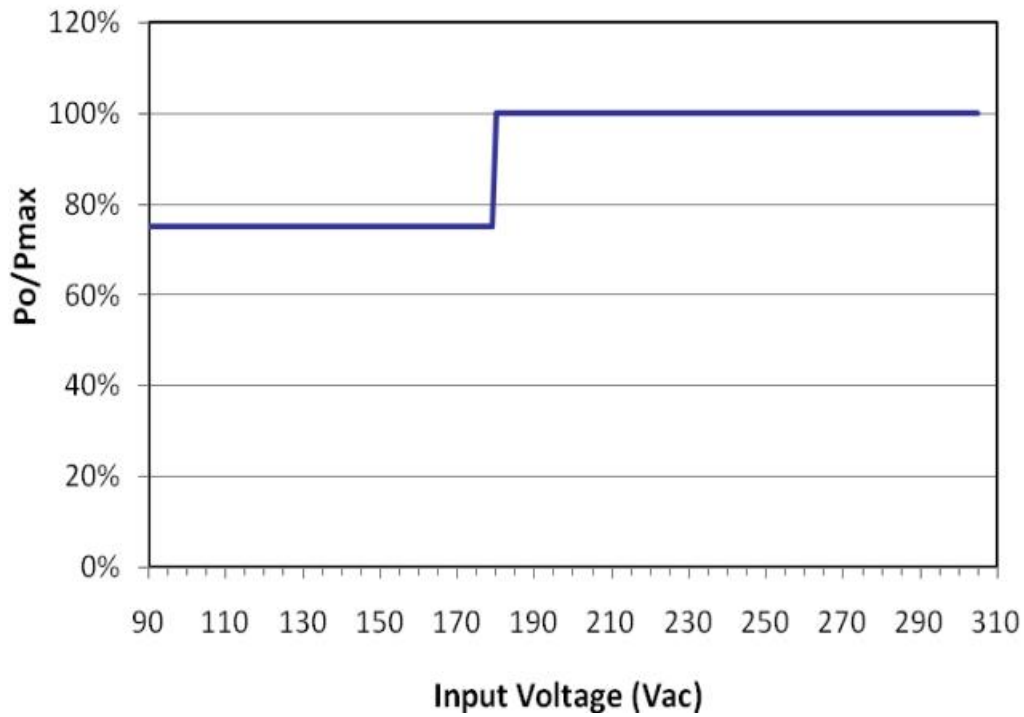

LIFETIME VS CASE TEMPERATURE

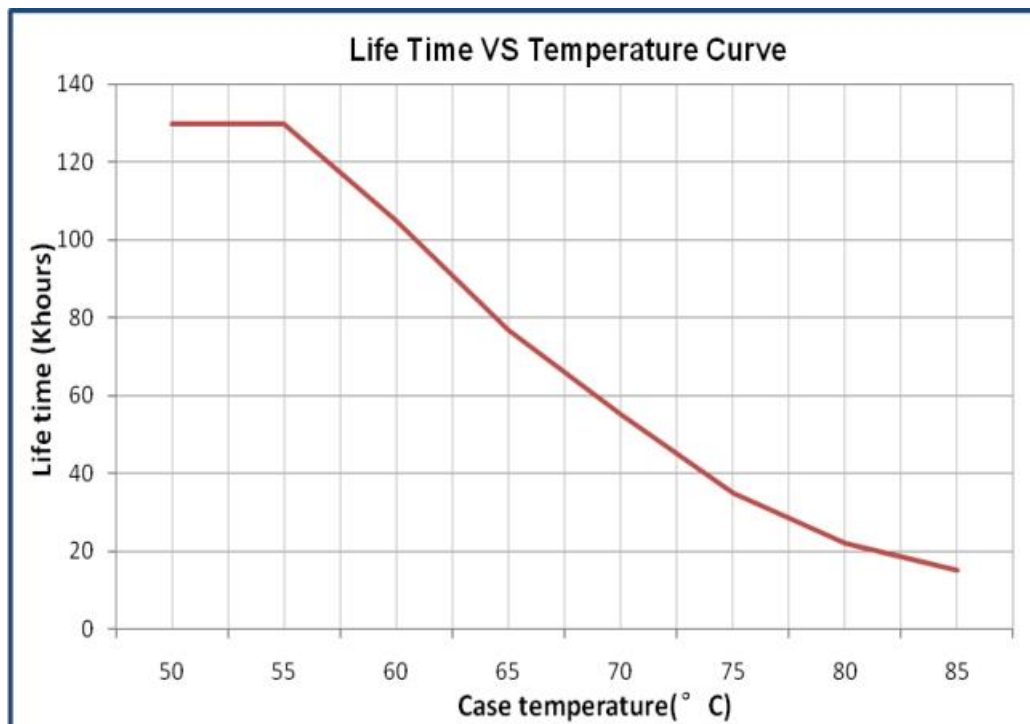

EFFICIENCY VS LOAD

GLUP-120X041Z (Vin=115Vac)

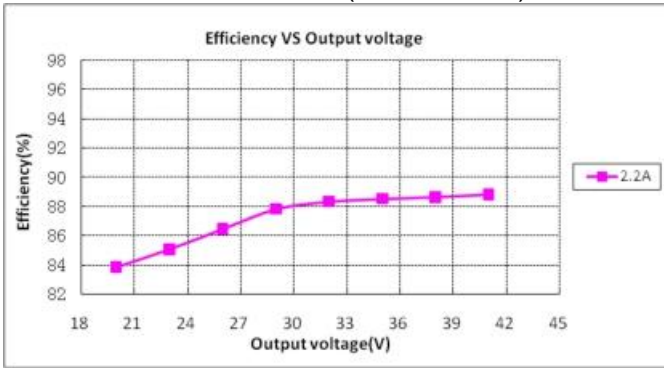

GLUP-120X041Z (Vin=230Vac)

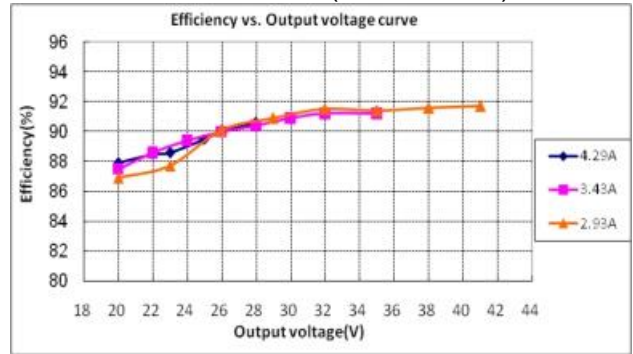

GLUP-120X041Z (Vin=277Vac)

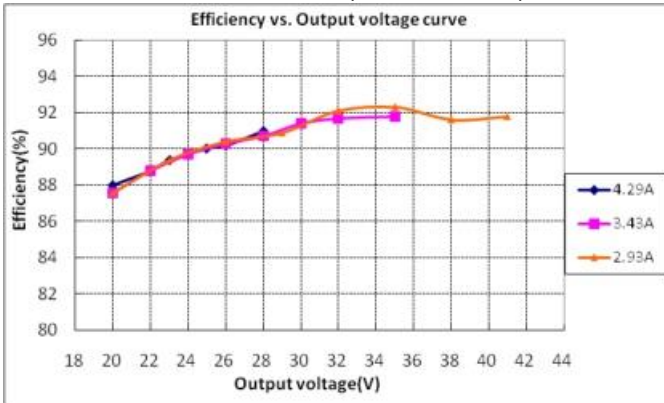

GLUP-120X062Z (Vin=115Vac)

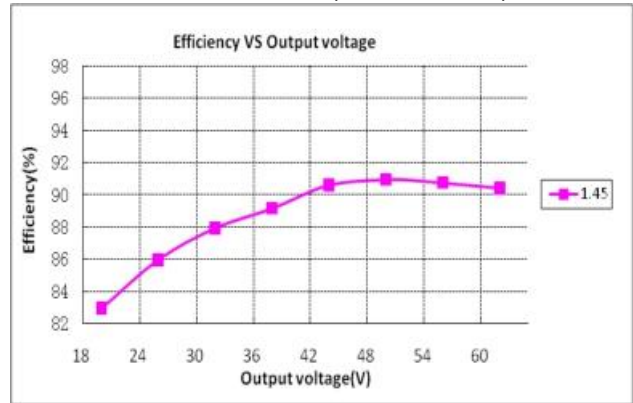

GLUP-120X062Z (Vin=230Vac)

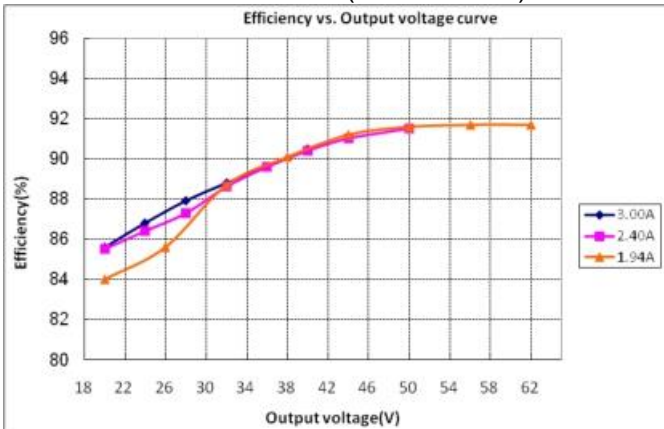

GLUP-120X062Z (Vin=277Vac)

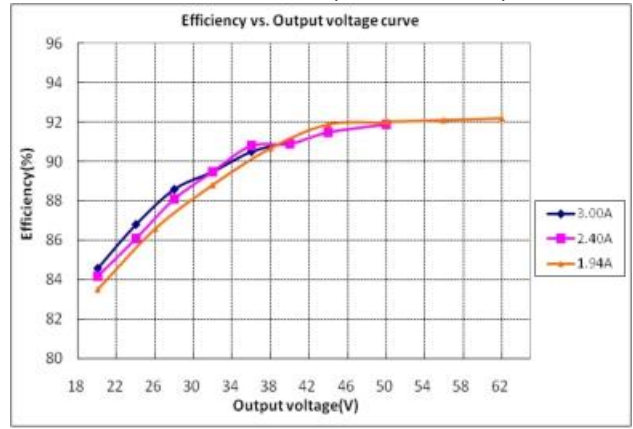

GLUP-120X170Z (Vin=115Vac)

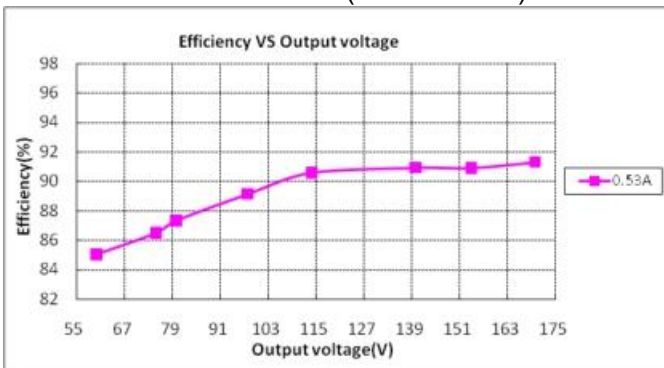

GLUP-120X170Z (Vin=230Vac)

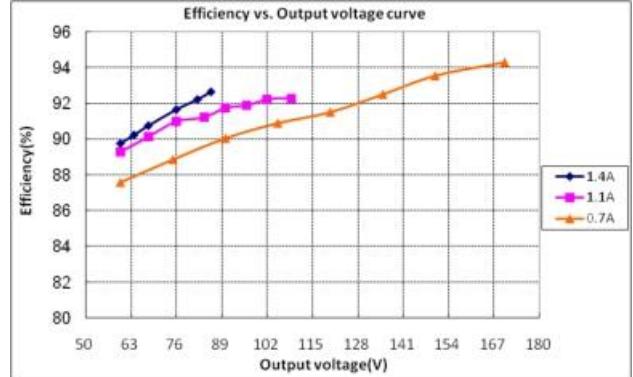

EFFICIENCY VS LOAD

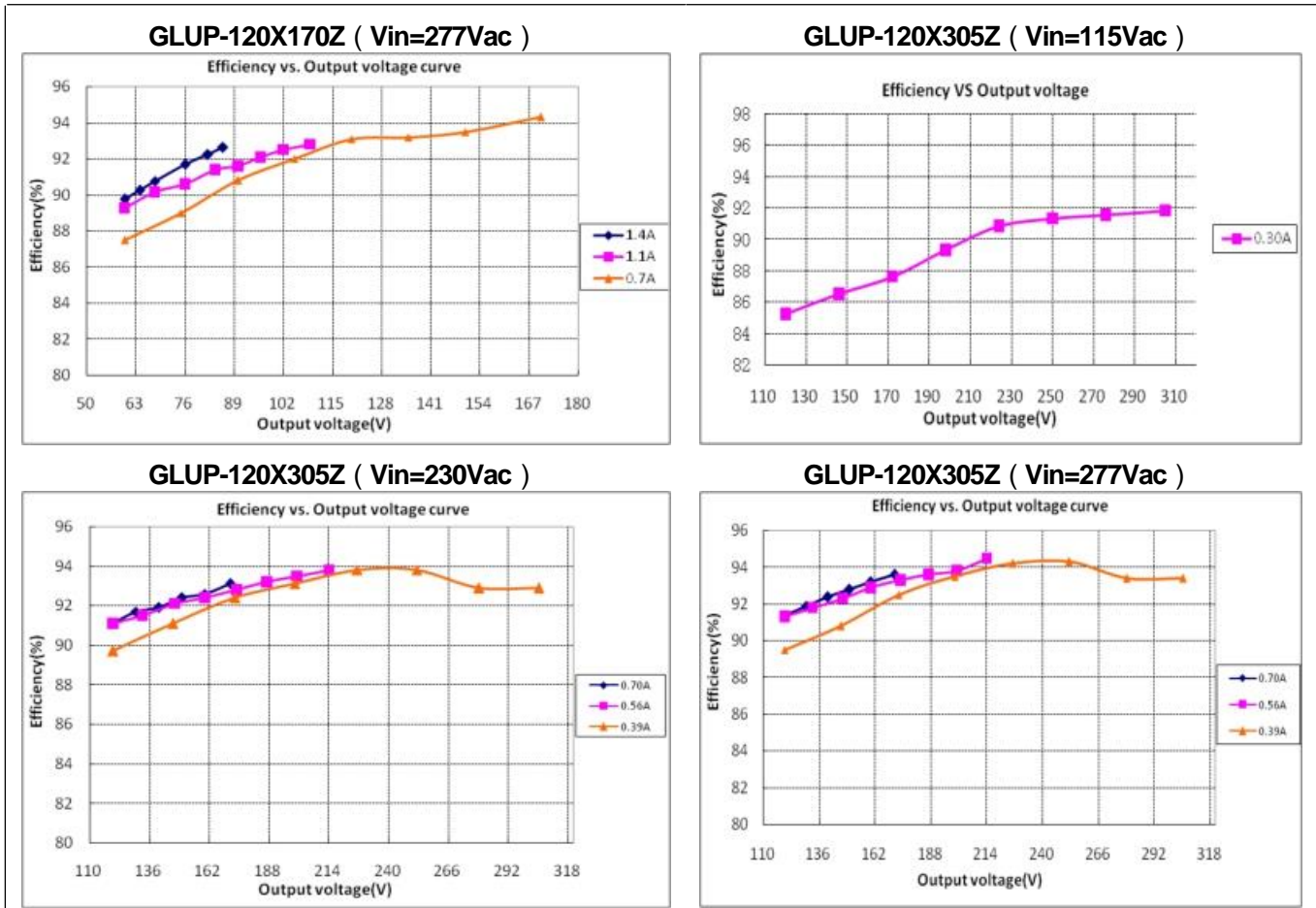

POWER FACTOR VS LOAD

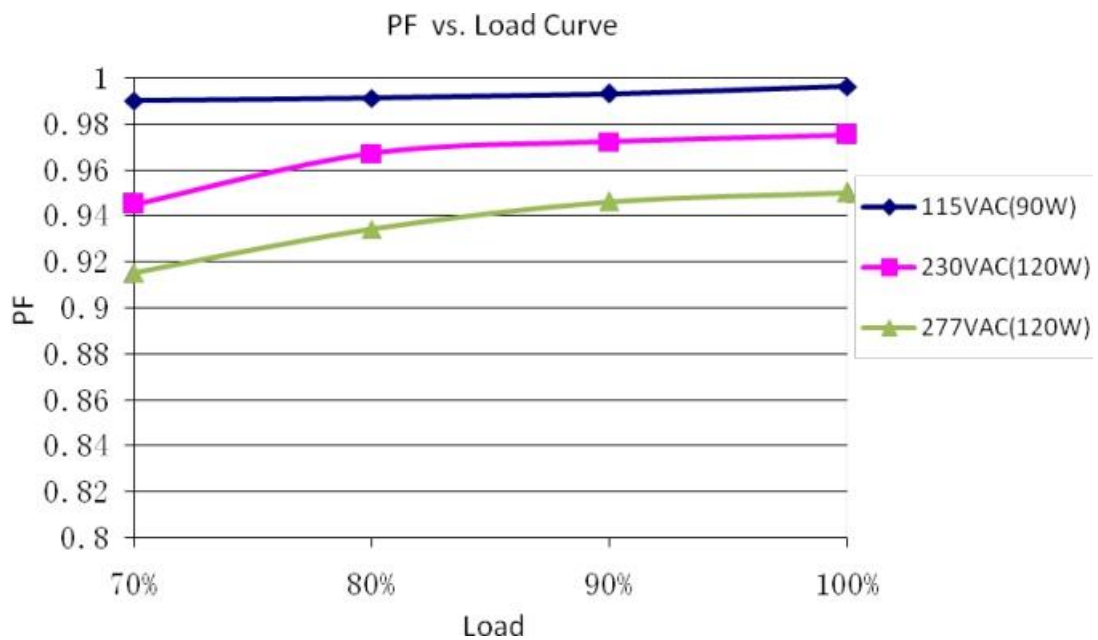

TOTAL HARMONIC DISTORTION

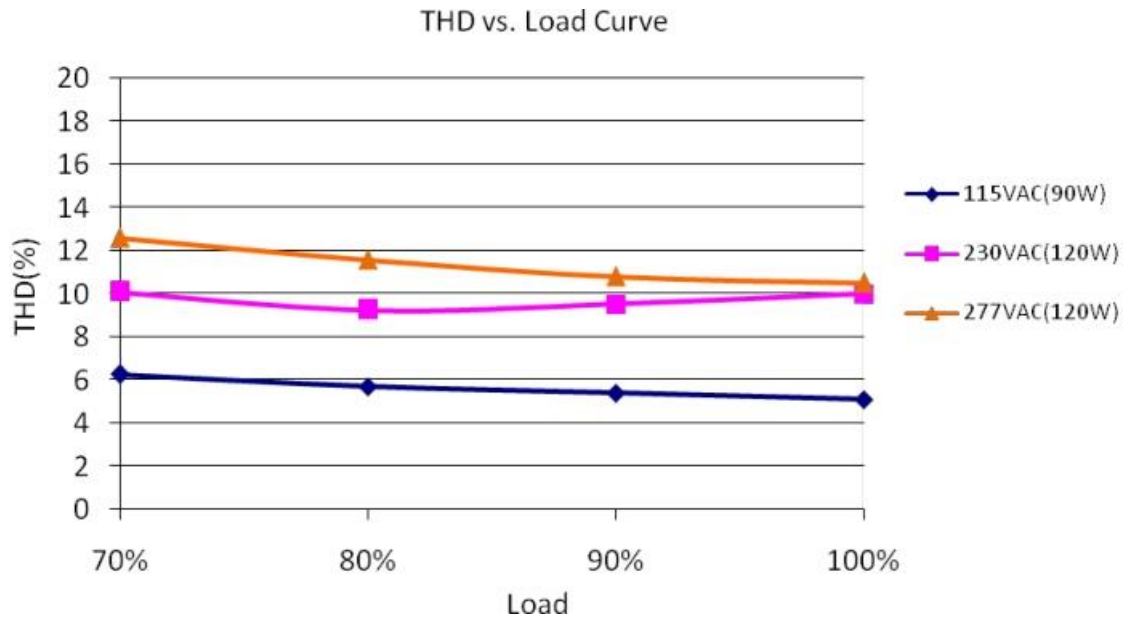

PROTECTIONS

Parameter	Notes
Over Temperature Protection	Decreases output current, returning to normal after over temperature is removed. The max derating could be 30% (typ.).
Short Circuit Protection	The input power shall decrease when the output rail short, the power supply shall not be damaged.
Over Voltage Protection	Run into protection model when output voltage exceeds limit, and return to normal when the fault

0-10V/PWM DIMMING

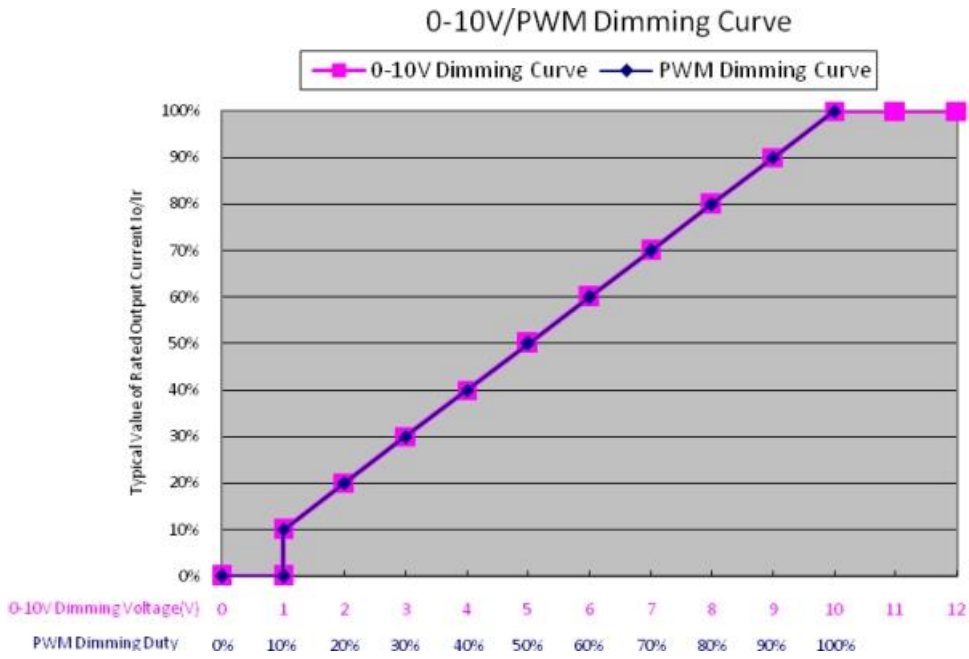

DALI DIMMING

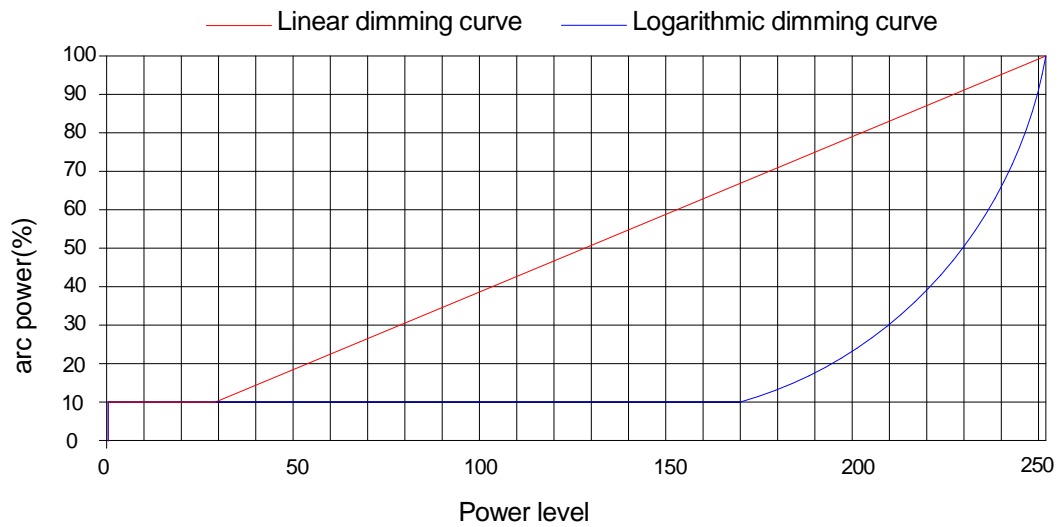

Note: Factory Default Output Logarithmic Curve

PROGRAMMING CONNECTION

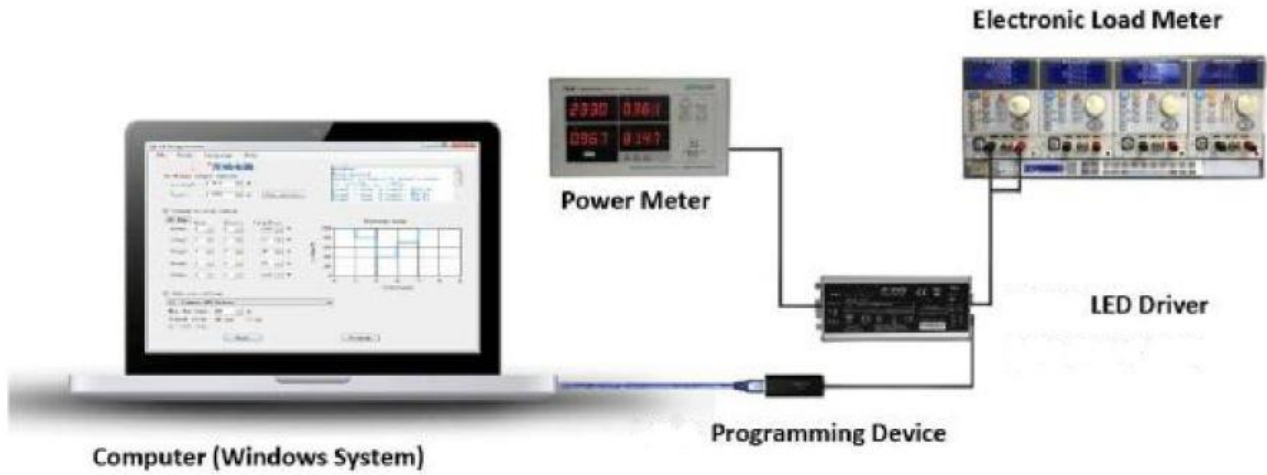

PROGRAMMING GUIDE AND SOFTWARE INTERFACE

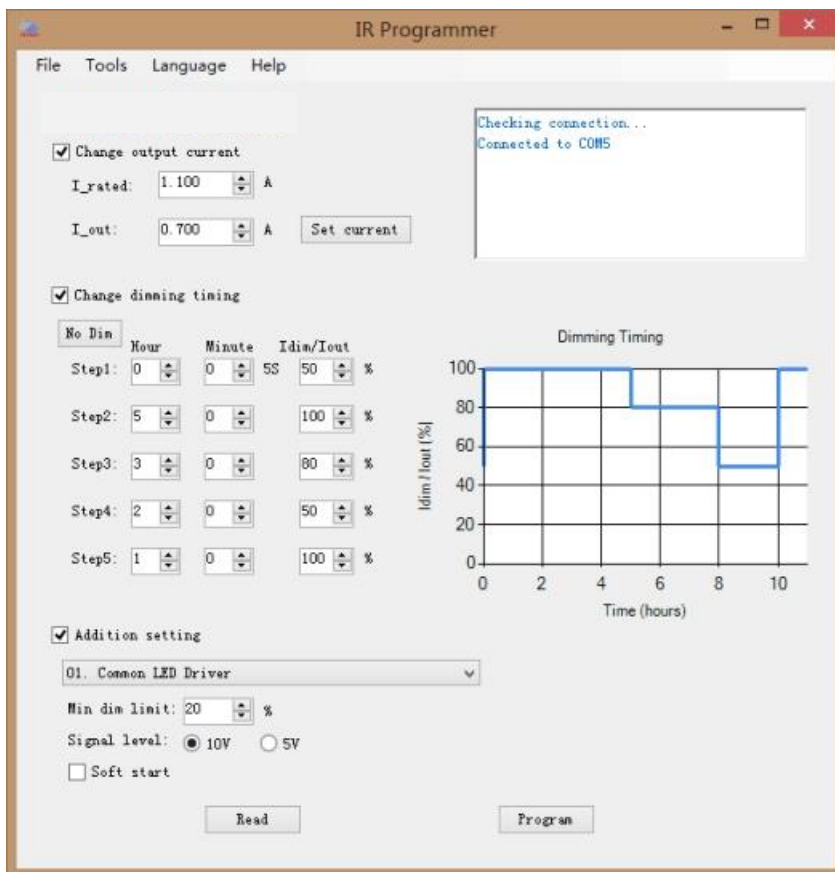

No Dim	Hour	Minute	SS	Idim/Iout	%
Step1:	0	0	55	50	100
Step2:	5	0		100	100
Step3:	3	0		80	80
Step4:	2	0		50	50
Step5:	1	0		100	100

Programming by Software:

- 1) Read existing setting of the driver
- 2) Change output current;
- 3) Set timer dimming schedules;
- 4) Addition setting
 - Set min. dim value;
 - Set signal level can be 5V or 10V;
 - Set soft start.

USING INFRARED CONTROLLER TO RESET OUTPUT CURRENT



Operation Instruction:

- 1) Insert cable terminal of the infrared controller into the infrared communication port, which is at the DC output side of the LED driver.
- 2) Press "ON" key to power on the controller;
- 3) Within 10S interval, press a function key to adjust output current to the percentage of max delivered current;
 - 10%-100%: Percentage of maximum output current of such driver.
 - + / - : Fine adjustment of output current, increase / decrease 1% each time.
 - ON: Power on controller.
 - OFF: Set min output current of such driver.
 - SE: No function.

Warning:

- Please do not hold "+"key, to avoid the over power protection and unstable output.
- Each step of operation should be done within 10S interval, otherwise the controller is power off automatically.

MECHANICAL OUTLINE

GLUP-120D types

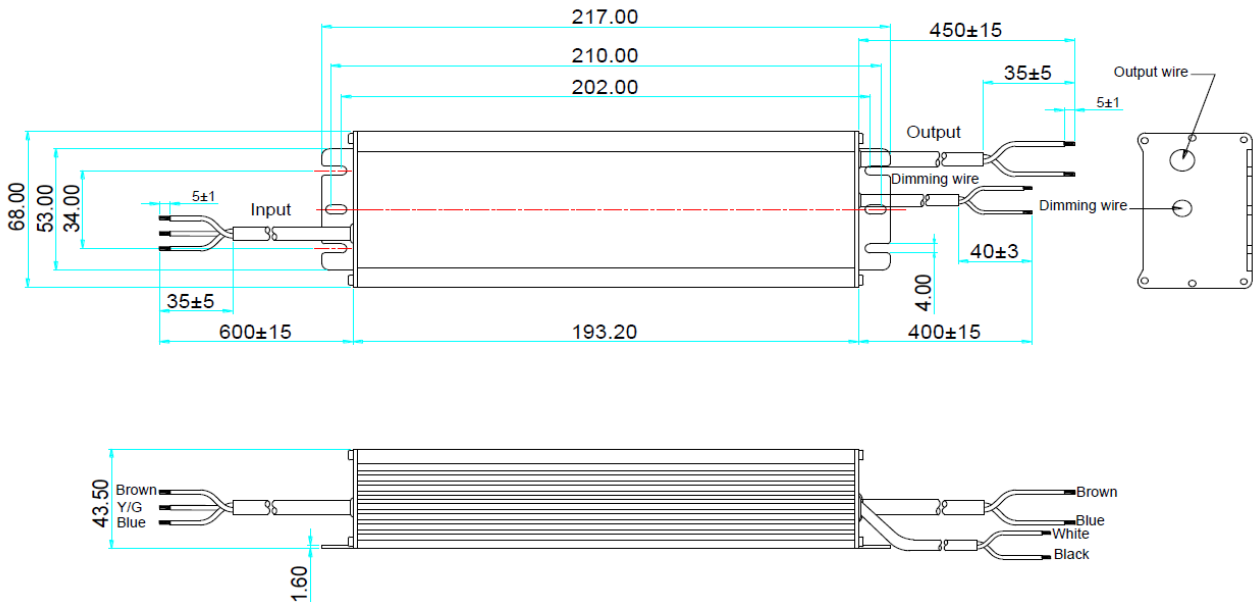

GLUP-120D-A12 types

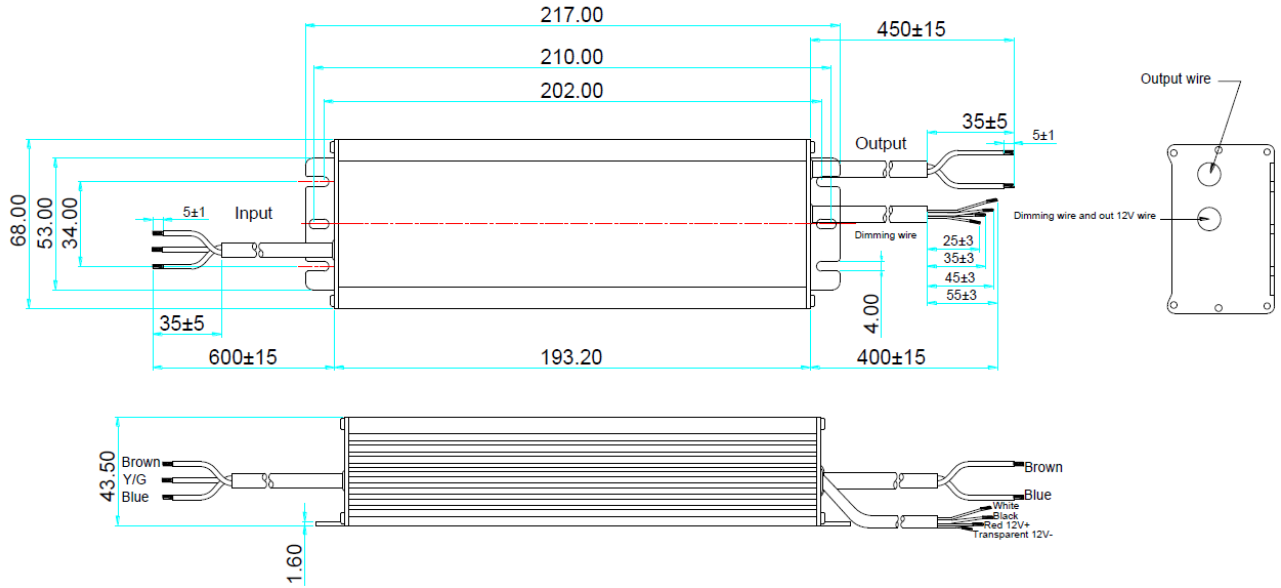

GLUP-120M types

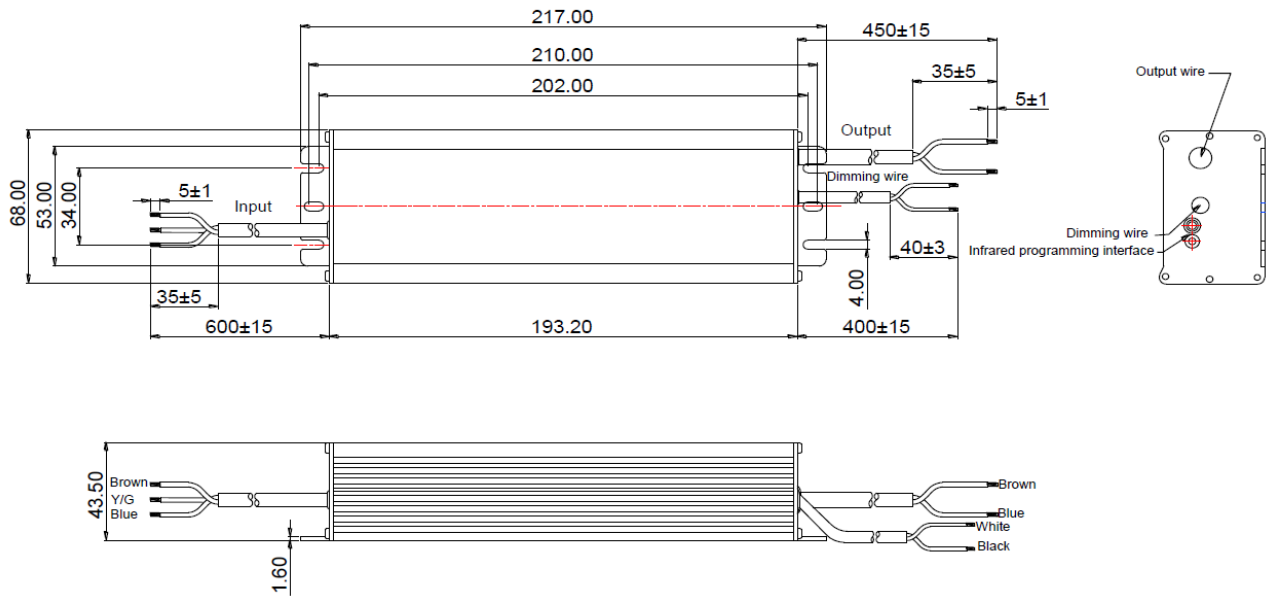

GLUP-120M-A12 types

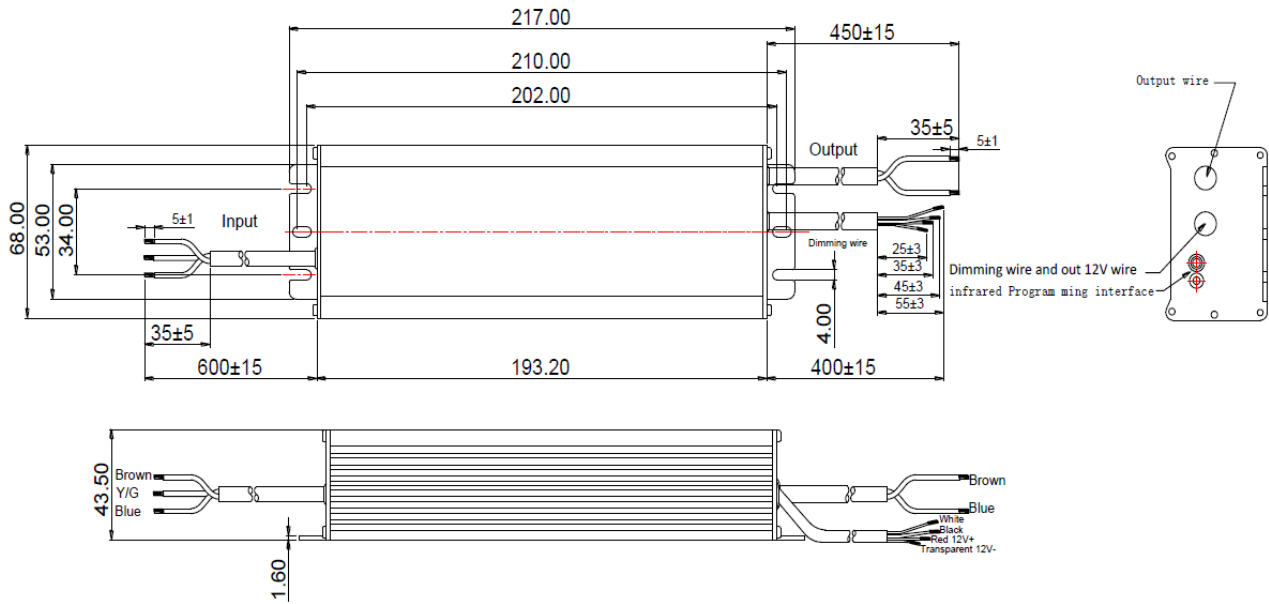

Wire	Specification
AC Input	CCC+VDE 3x1.0mm ² L=600mm
DC Output	CCC+VDE 2x1.0mm ² L=450mm
Dimming	22# 2C L=400mm
	22# 4C L=400mm